



National  
Measurement  
Institute

NMI M6-1



**Overview**

The PMC-220 Single-Phase Multifunction Meter is CET's latest offer for the low voltage energy metering market featuring DIN-Rail mount, compact construction, 63A direct connect input and high accuracy measurements. The PMC-220 complies with the IEC 62053-21: 2020 Class 0.5 kWh Accuracy Standard. In addition, the PMC-220 has received the Certificate of Approval from the National Measurement Institute (NMI) of Australia and been verified by UL with reference to NMI M6-1 Electricity Meters, Part 1: Metrological and Technical Requirements. With the standard RS-485 port and Modbus RTU protocol, the PMC-220 becomes a vital component of an intelligent, multifunction monitoring solution for any Energy Management Systems.

**Features**

- IEC 62053-21: 2020 Class 0.5 Compliant and NMI M6-1 Class 1 Certified
- Direct Input up to 63A without external CT
- Low Starting Current @ 20mA
- Multifunction measurements
  - Voltage, Current, kW, kvar, kVA, PF and Frequency
  - kWh and kvarh Imp/Exp/Tot/Net and kVAh
  - Device Operating Time (Running Hour)
  - Front Panel & Communication Programming Counters
- 8-digit Multifunction LCD Display
- Self-powered, no external control power required
- kWh LED Pulse Output
- Solid State Energy Pulse Output @ 1000 imp/kxh
- A standard RS-485 port with Modbus RTU support
- Easy installation with DIN-Rail mounting, no tools required

**Front Panel Display**



**Accuracy**

Parameters	Accuracy	Resolution
Voltage	±0.5% reading	0.1V
Current	±0.5% reading	0.001A
kW, kVA	±1.0%	0.001kX
kvar	±1.0%	0.001kvar
kWh	IEC 62053-21: 2020 Class 0.5 NMI M6-1 Class 1	0.01kWh
kvarh	IEC 62053-23: 2020 Class 2	0.01kvarh
kVAh	IEC 62053-21: 2020 Class 0.5	0.01kVAh
PF	±1.0%	0.001
Frequency	±0.02Hz	0.01Hz

**Dimensions and Installation**

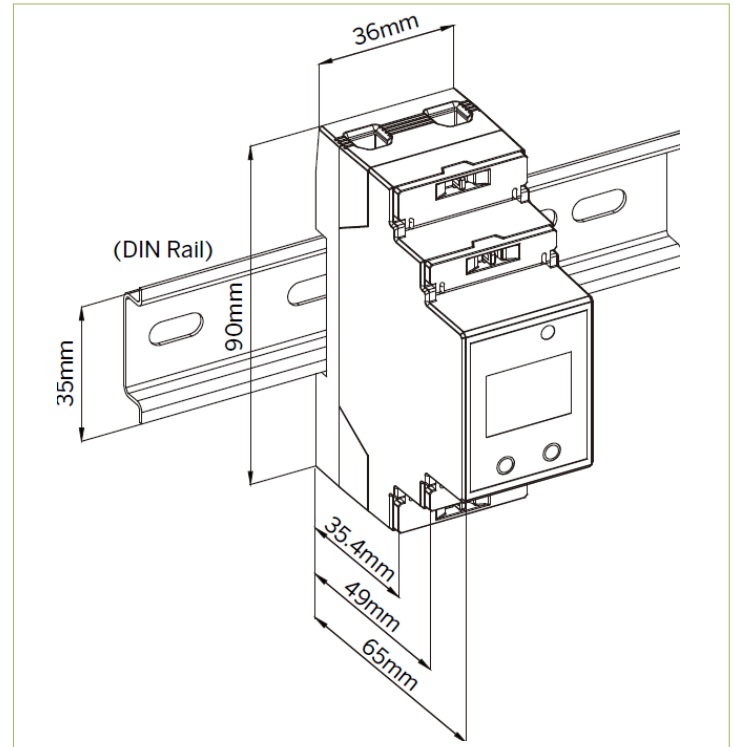

**Terminals and Wiring Diagram**

No.	Terminal	Labels	Description
1	1   2	L, N	Input Terminals
2	5   6	E+, E-	Pulse Output Terminals
3	7   8	D+, D-	RS-485 Terminals
4	3   4	L', N'	Output Terminals



**Technical Specifications**

Measurement Inputs (L, N, L', N')	
Voltage (Un)	220VAC 230VAC 240VAC
Overrange (% Un)	120% 115% 110%
Range (V)	95-264VAC
Current (Ib / Imax)	5A / 63A
Starting Current (Ist)	0.4% Ib (0.02A)
Minimum Current (Imin)	5% Ib (0.25A)
Burden	<2VA
Frequency	45Hz-65Hz
Power Supply	Self-powered from 95 to 264VAC
Maximum Wire Size	25 mm <sup>2</sup> (4AWG)
Torque for L, N Terminals	2.5 N.m
Communications (D+, D-)	
RS-485 (Modbus RTU)	Optically isolated @ 5kVrms
Baud Rate	1200/2400/4800/9600/19200 bps
Maximum Wire Size	1.5mm <sup>2</sup> (16AWG)
Torque for RS-485 Terminals	0.45 N.m
Pulse Output (E+, E-)	
Type	Optically Isolated Solid State Relay
Max. Load Voltage	80 VDC
Max. Forward Current	50 mA
Maximum Wire Size	1.5 mm <sup>2</sup> (16AWG)
Pulse Constant	1000 imp/kxh
Pulse Width	60-100 ms
Torque for RS-485 Terminals	0.45 N.m
Environmental Conditions	
Operating Temp.	-25°C to +70°C
Storage Temp.	-40°C to +85°C
Humidity	5% to 95% non-condensing
Atmospheric Pressure	70kPa to 106kPa
Pollution Degree	2
Mechanical Characteristics	
Unit Dimensions	36x65x90mm
Shipping Weight	0.18kg
Shipping Dimensions	120x103x42mm
Mounting	DIN-Rail Mounting
IP Rating	IP51 (Front), IP30 (Body)

**Modbus Map**

Register	Property	Description	Format	Scale/Unit
0000	RO	V	Float	V
0002	RO	I	Float	A
0004	RO	kW	Float	kW
0006	RO	kvar	Float	kvar
0008	RO	kVA	Float	kVA
0010	RO	PF	Float	-
0012	RO	Frequency	Float	Hz
0014-0037		Reserved		
0038	RO	FP Counter	UINT16	1
0039	RO	Comm. Counter	UINT16	1
0040	RW	kWh Import	INT32	x0.01, kWh
0042	RW	kWh Export	INT32	x0.01, kWh
0044	RO	kWh Net	INT32	x0.01, kWh
0046	RO	kWh Total	INT32	x0.01, kWh
0048	RW	kvarh Import	INT32	x0.01, kvarh
0050	RW	kvarh Export	INT32	x0.01, kvarh
0052	RO	kvarh Net	INT32	x0.01, kvarh
0054	RO	kvarh Total	INT32	x0.01, kvarh
0056	RW	kVAh	INT32	x0.01, kVAh
0058	RO	Operating Time	UINT32	x0.1, h

**Standards of Compliance**

Safety Requirements	
CE LVD 2014/35/EU	EN 61010-1: 2010 + A1: 2019 EN 61010-2-030: 2010
Insulation (Indoor Use)	IEC 62052-31: 2015 AS 62052-31: 2017
AC Voltage	NMI M6-1
Impulse Voltage	4kV @ 1 minute 12kV+0%, -15%, 1.2/50µs (NMI M6-1)
Electrical Safety in Low Voltage Distribution Systems up to 1000Vac and 1500Vdc	IEC 61557-12: 2018 (PMD)
Electromagnetic Compatibility	
EMC 2014/30/EU (EN 61326: 2013)	
Electrostatic Discharge	EN 61000-4-2: 2009
Radiated Fields	EN 61000-4-3: 2006+A1: 2008+A2: 2010
Fast Transients	EN 61000-4-4: 2012
Surges	EN 61000-4-5: 2014 + A1: 2017
Conducted Disturbances	EN 61000-4-6: 2014
Magnetic Fields	EN 61000-4-8: 2010
Voltage Dips and Interruptions	EN 61000-4-11: 2004 + A1: 2017
Ring Waves	EN 61000-4-12: 2017
Mechanical Tests	
Spring Hammer Test	IEC 62052-31: 2015
Vibration Test	IEC 62052-11: 2020
Shock Test	IEC 62052-11: 2020
Revenue Metering Approval	
NMI M6-1 of Australia	Approval Mark: NMI 14/2/98 UL Ref. # R11353641-CETA-NMI M6-1

**Ordering Information**

Product Code	Description
PMC-220	Digital Single-Phase Energy Meter
	Input Current
C	5A (63A Max), Direct Input
	Input Voltage
3	95V-240V AC ±10%
	System Frequency
5	45Hz-65Hz
	Communications
A	1xRS-485
	Language
E	English
PMC-220 - C 3 5 A E	PMC-220-C35AE (Standard Model)

**Your Local Representative**

